

UC2838, UC2838A UC3838, UC3838A

SLUS221A – APRIL 2000 – REVISED MAY 2001

description (continued)

The UC3838/A contains a precision 2.5-V reference, two uncommitted high-gain operational amplifier and a high-gain PNP-equivalent current source which can deliver up to 100 mA of magnetic amplifier reset current and with -120-V capability.

These devices are available in a plastic batwing DIP (N), wide body SOIC (DW), and PLCC (Q) package for operation over a -20°C to 85°C temperature range.

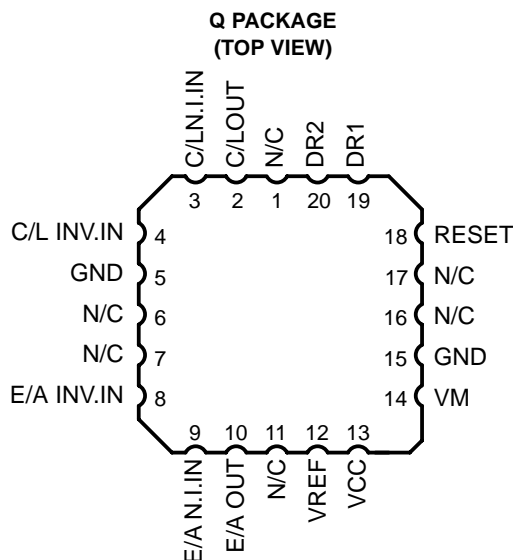
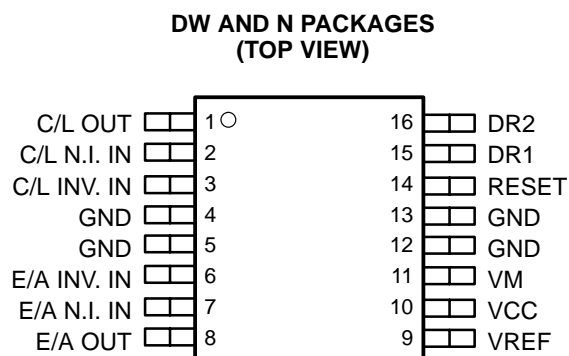

absolute maximum ratings over operating free-air temperature (unless otherwise noted)[†]

Supply voltage, V_{CC}	40 V
Magnetic amplifier source voltage, V_M	40 V
Reset output voltage, V_R	-120 V
Total current source voltage, $V_M - V_R$	-140 V
Amplifier input range	-0.3 V to V_{CC}
Reset input current, DR1 and DR2	-10 mA
Power dissipation at $T_A = 25^{\circ}\text{C}$	
Q, N, DW package	2 W
Power dissipation at T (leads/case) = 25°C	
Q, N, DW package	5 W
Operating temperature range, T_J	-55°C to 125°C
Storage temperature range, T_{stg}	-65°C to 150°C
Lead temperature (soldering, 10 sec)	300°C

[†] Stresses beyond those listed under "absolute maximum ratings" may cause permanent damage to the device. These are stress ratings only, and functional operation of the device at these or any other conditions beyond those indicated under "recommended operating conditions" is not implied. Exposure to absolute-maximum-rated conditions for extended periods may affect device reliability.

[‡] All voltages are with respect to ground pins. All currents are positive into the specified terminal. Consult packaging section of data book for thermal limitations and considerations of package.

electrical characteristics, $T_A = -20^{\circ}\text{C}$ to 85°C for the UC2838/A, and $T_A = 0^{\circ}\text{C}$ to 70°C for the UC3838/A, $V_{CC} = 20\text{ V}$, $V_M = 5\text{ V}$, $T_A = T_J$, (unless otherwise stated)

reference

PARAMETER	TEST CONDITIONS	UC2838/UC2838A			UC3838/UC3838A			UNITS
		MIN	TYP	MAX	MIN	TYP	MAX	
Supply current	$V_{CC} = V_M = 40\text{ V}$		4	8		4	8	mA
Reference output	$T_A = 25^{\circ}\text{C}$	2.47	2.50	2.53	2.45	2.50	2.55	V
Line regulation	$V_{CC} = 5\text{ V}$ to 30 V		1	5		1	10	mV
Load regulation	$I_O = 0\text{ mA}$ to -2 mA		5	20		5	20	mV
Short-circuit current	$V_{REF} = 0\text{ V}$		-30	-60		-30	-60	mA
Temperature stability	See Note 1		15	25		10	25	mV

NOTE: 1. These parameters are ensured by design but not 100% tested in production.

amplifier (each amplifier)

PARAMETER	TEST CONDITIONS	UC2838/UC2838A			UC3838/UC3838A			UNITS
		MIN	TYP	MAX	MIN	TYP	MAX	
Offset voltage	$V_{CM} = 2.5\text{ V}$			5			10	mV
Input bias current	$V_{IN} = 0\text{ V}$			-1			-1	μA
Input offset voltage				100			100	nA
Minimum output swing		0.4		18	0.4		18	V
Output sink current	$V_O = 5\text{ V}$	1	10	30	1	10	30	mA
Output source current	$V_O = 0\text{ V}$	-1	-10	-20	-1	-10	-20	mA
A_{VOL} (open loop gain)	$V_O = 1\text{ V}$ to 11 V	100	120		100	120		dB
C_{MRR} (common mode rejection ratio)	$V_{IN} = 1\text{ V}$ to 11 V	70	80		70	80		dB
PSRR (power supply rejection ratio)	$V_{CC} = 10\text{ V}$ to 20 V	70	100		70	100		dB
Gain bandwidth	See Note 1	0.6	0.8		0.6	0.8		MHz

NOTE: 1. These parameters are ensured by design but not 100% tested in production.

reset drive

PARAMETER	TEST CONDITIONS	UC2838/UC2838A			UC3838/UC3838A			UNITS
		MIN	TYP	MAX	MIN	TYP	MAX	
Input leakage	$V_{DR} = 40\text{ V}$			10			10	μA
Output leakage	$V_R = -120\text{ V}$			-100			-100	μA
Input current	$I_R = -50\text{ mA}$		-1	-2		-1	-2	mA
Maximum reset current	$I_{DR} = -3\text{ mA}$	-100	-120	-200	-100	-120	-200	mA
Transconductance	$I_R = -10\text{ mA}$ to -50 mA	0.03	0.042	0.055	0.03	0.042	0.055	A/V

typical application

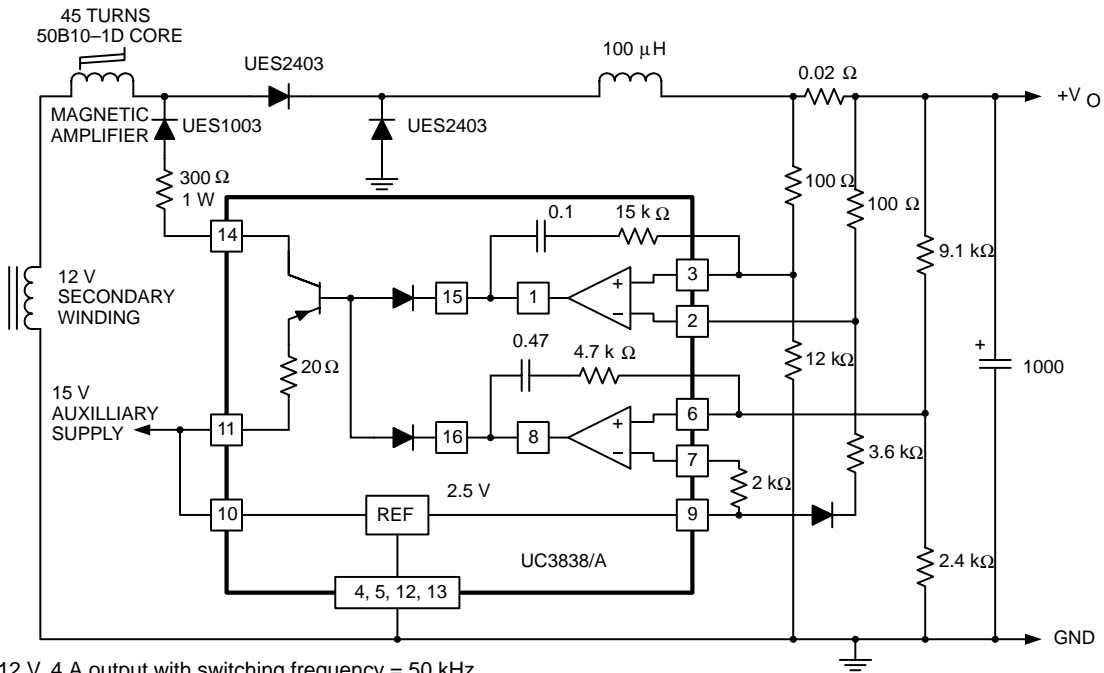

NOTE: 12 V, 4 A output with switching frequency = 50 kHz.

APPLICATION INFORMATION

**GAIN MAGNITUDE/PHASE
 VS
 SIGNAL FREQUENCY**

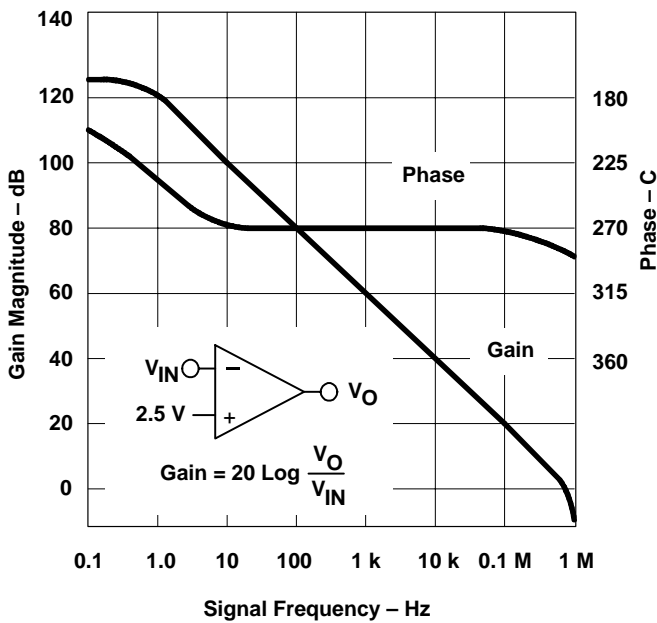

Figure 1.

**GAIN MAGNITUDE
 VS
 SIGNAL FREQUENCY**

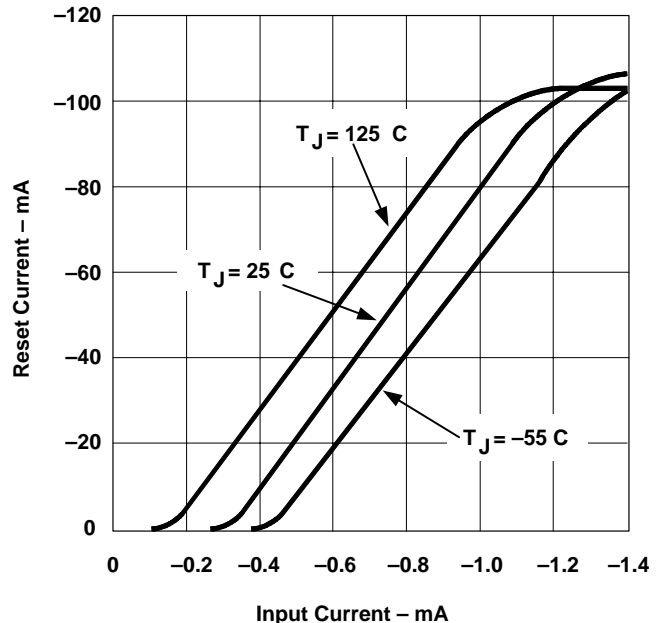

Figure 2.

APPLICATION INFORMATION

RESET CURRENT
vs
RESET VOLTAGE

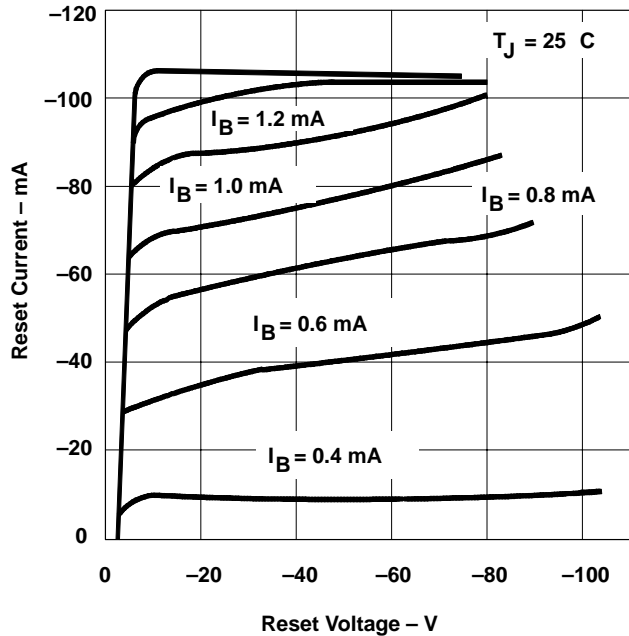

Figure 3.

GAIN MAGNITUDE/PHASE
vs
SIGNAL FREQUENCY

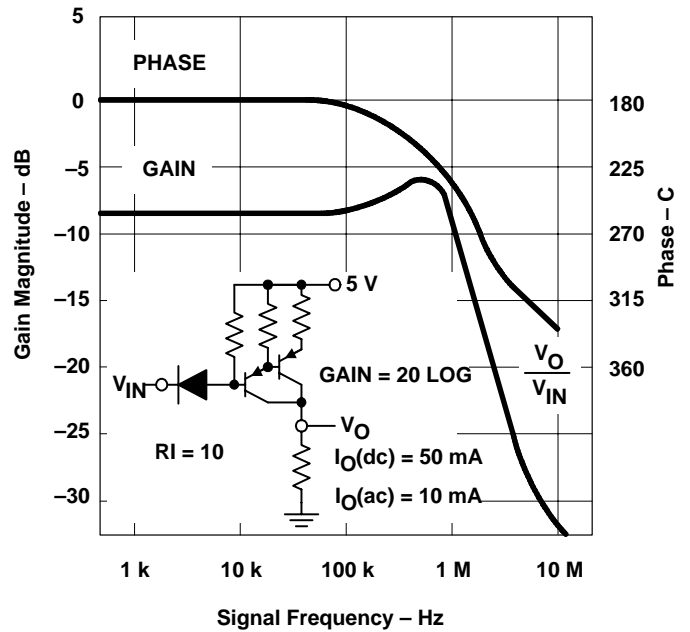

Figure 4.

RESET CURRENT
vs
INPUT CURRENT

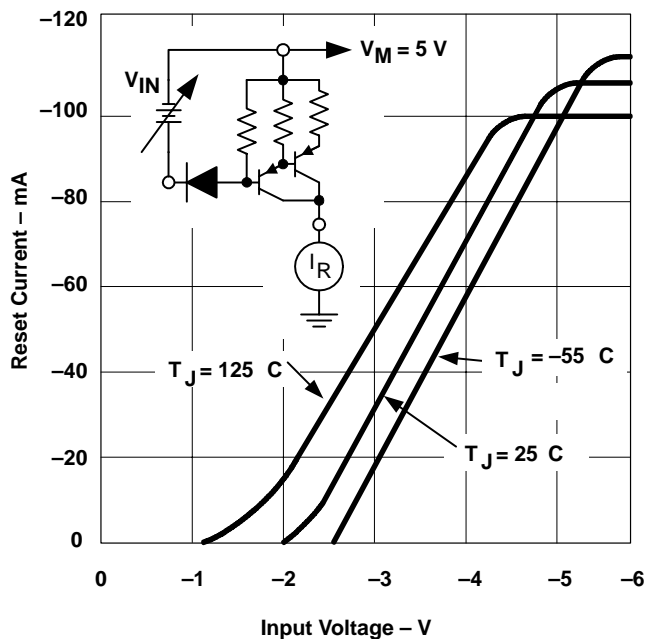

Figure 5.

REFERENCE VOLTAGE OUTPUT
vs
JUNCTION TEMPERATURE

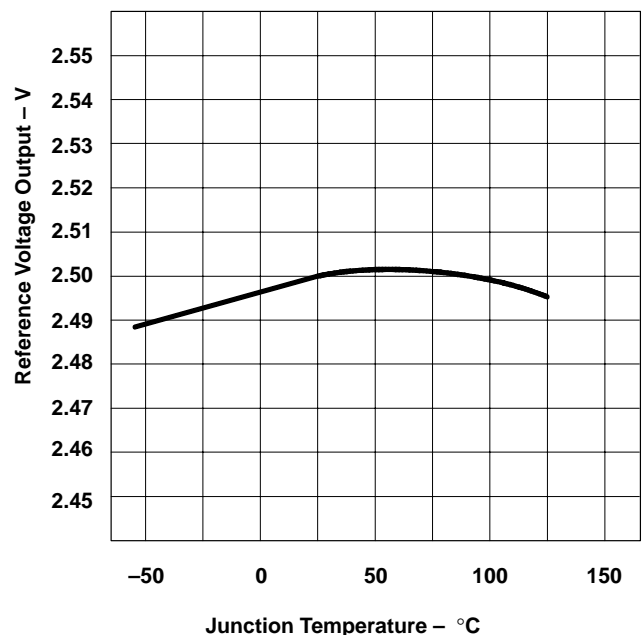

Figure 6.

PACKAGING INFORMATION

Orderable Device	Status ⁽¹⁾	Package Type	Package Drawing	Pins	Package Qty	Eco Plan ⁽²⁾	Lead/Ball Finish	MSL Peak Temp ⁽³⁾
UC2838AJ	NRND	CDIP	J	16		TBD	Call TI	Call TI
UC2838AN	NRND	PDIP	N	16	25	Green (RoHS & no Sb/Br)	CU NIPDAU	N / A for Pkg Type
UC2838ANG4	NRND	PDIP	N	16	25	Green (RoHS & no Sb/Br)	CU NIPDAU	N / A for Pkg Type
UC2838AQ	NRND	PLCC	FN	20		TBD	Call TI	Call TI
UC2838AQTR	OBSOLETE	PLCC	FN	20		TBD	Call TI	Call TI
UC3838ADW	OBSOLETE	SOIC	DW	16		TBD	Call TI	Call TI

⁽¹⁾ The marketing status values are defined as follows:

ACTIVE: Product device recommended for new designs.

LIFEBUY: TI has announced that the device will be discontinued, and a lifetime-buy period is in effect.

NRND: Not recommended for new designs. Device is in production to support existing customers, but TI does not recommend using this part in a new design.

PREVIEW: Device has been announced but is not in production. Samples may or may not be available.

OBSOLETE: TI has discontinued the production of the device.

⁽²⁾ Eco Plan - The planned eco-friendly classification: Pb-Free (RoHS), Pb-Free (RoHS Exempt), or Green (RoHS & no Sb/Br) - please check <http://www.ti.com/productcontent> for the latest availability information and additional product content details.

TBD: The Pb-Free/Green conversion plan has not been defined.

Pb-Free (RoHS): TI's terms "Lead-Free" or "Pb-Free" mean semiconductor products that are compatible with the current RoHS requirements for all 6 substances, including the requirement that lead not exceed 0.1% by weight in homogeneous materials. Where designed to be soldered at high temperatures, TI Pb-Free products are suitable for use in specified lead-free processes.

Pb-Free (RoHS Exempt): This component has a RoHS exemption for either 1) lead-based flip-chip solder bumps used between the die and package, or 2) lead-based die adhesive used between the die and leadframe. The component is otherwise considered Pb-Free (RoHS compatible) as defined above.

Green (RoHS & no Sb/Br): TI defines "Green" to mean Pb-Free (RoHS compatible), and free of Bromine (Br) and Antimony (Sb) based flame retardants (Br or Sb do not exceed 0.1% by weight in homogeneous material)

⁽³⁾ MSL, Peak Temp. -- The Moisture Sensitivity Level rating according to the JEDEC industry standard classifications, and peak solder temperature.

Important Information and Disclaimer:The information provided on this page represents TI's knowledge and belief as of the date that it is provided. TI bases its knowledge and belief on information provided by third parties, and makes no representation or warranty as to the accuracy of such information. Efforts are underway to better integrate information from third parties. TI has taken and continues to take reasonable steps to provide representative and accurate information but may not have conducted destructive testing or chemical analysis on incoming materials and chemicals. TI and TI suppliers consider certain information to be proprietary, and thus CAS numbers and other limited information may not be available for release.

In no event shall TI's liability arising out of such information exceed the total purchase price of the TI part(s) at issue in this document sold by TI to Customer on an annual basis.

OTHER QUALIFIED VERSIONS OF UC3838A :

- Military: [UC1838A](#)

NOTE: Qualified Version Definitions:

- Military - QML certified for Military and Defense Applications

IMPORTANT NOTICE

Texas Instruments Incorporated and its subsidiaries (TI) reserve the right to make corrections, modifications, enhancements, improvements, and other changes to its products and services at any time and to discontinue any product or service without notice. Customers should obtain the latest relevant information before placing orders and should verify that such information is current and complete. All products are sold subject to TI's terms and conditions of sale supplied at the time of order acknowledgment.

TI warrants performance of its hardware products to the specifications applicable at the time of sale in accordance with TI's standard warranty. Testing and other quality control techniques are used to the extent TI deems necessary to support this warranty. Except where mandated by government requirements, testing of all parameters of each product is not necessarily performed.

TI assumes no liability for applications assistance or customer product design. Customers are responsible for their products and applications using TI components. To minimize the risks associated with customer products and applications, customers should provide adequate design and operating safeguards.

TI does not warrant or represent that any license, either express or implied, is granted under any TI patent right, copyright, mask work right, or other TI intellectual property right relating to any combination, machine, or process in which TI products or services are used. Information published by TI regarding third-party products or services does not constitute a license from TI to use such products or services or a warranty or endorsement thereof. Use of such information may require a license from a third party under the patents or other intellectual property of the third party, or a license from TI under the patents or other intellectual property of TI.

Reproduction of TI information in TI data books or data sheets is permissible only if reproduction is without alteration and is accompanied by all associated warranties, conditions, limitations, and notices. Reproduction of this information with alteration is an unfair and deceptive business practice. TI is not responsible or liable for such altered documentation. Information of third parties may be subject to additional restrictions.

Resale of TI products or services with statements different from or beyond the parameters stated by TI for that product or service voids all express and any implied warranties for the associated TI product or service and is an unfair and deceptive business practice. TI is not responsible or liable for any such statements.

TI products are not authorized for use in safety-critical applications (such as life support) where a failure of the TI product would reasonably be expected to cause severe personal injury or death, unless officers of the parties have executed an agreement specifically governing such use. Buyers represent that they have all necessary expertise in the safety and regulatory ramifications of their applications, and acknowledge and agree that they are solely responsible for all legal, regulatory and safety-related requirements concerning their products and any use of TI products in such safety-critical applications, notwithstanding any applications-related information or support that may be provided by TI. Further, Buyers must fully indemnify TI and its representatives against any damages arising out of the use of TI products in such safety-critical applications.

TI products are neither designed nor intended for use in military/aerospace applications or environments unless the TI products are specifically designated by TI as military-grade or "enhanced plastic." Only products designated by TI as military-grade meet military specifications. Buyers acknowledge and agree that any such use of TI products which TI has not designated as military-grade is solely at the Buyer's risk, and that they are solely responsible for compliance with all legal and regulatory requirements in connection with such use.

TI products are neither designed nor intended for use in automotive applications or environments unless the specific TI products are designated by TI as compliant with ISO/TS 16949 requirements. Buyers acknowledge and agree that, if they use any non-designated products in automotive applications, TI will not be responsible for any failure to meet such requirements.

Following are URLs where you can obtain information on other Texas Instruments products and application solutions:

Products

Amplifiers	amplifier.ti.com
Data Converters	dataconverter.ti.com
DSP	dsp.ti.com
Clocks and Timers	www.ti.com/clocks
Interface	interface.ti.com
Logic	logic.ti.com
Power Mgmt	power.ti.com
Microcontrollers	microcontroller.ti.com
RFID	www.ti-rfid.com
RF/IF and ZigBee® Solutions	www.ti.com/lprf

Applications

Audio	www.ti.com/audio
Automotive	www.ti.com/automotive
Broadband	www.ti.com/broadband
Digital Control	www.ti.com/digitalcontrol
Medical	www.ti.com/medical
Military	www.ti.com/military
Optical Networking	www.ti.com/opticalnetwork
Security	www.ti.com/security
Telephony	www.ti.com/telephony
Video & Imaging	www.ti.com/video
Wireless	www.ti.com/wireless

Mailing Address: Texas Instruments, Post Office Box 655303, Dallas, Texas 75265
Copyright © 2008, Texas Instruments Incorporated